

Battery selector cable (black)

- Not connected = **14.4V charge voltage**
- Connected to minus = **14.7V charge voltage**
- Connected to +12V = **LiFePO4**

Smart alternator cable (red)

- Not connected = **Conventional alternator**
- Connected to ignition = **Smart alternator**

RED = Smart Alternator cable
BLACK = Battery selector

RED = Smart Alternator cable
BLACK = Battery selector

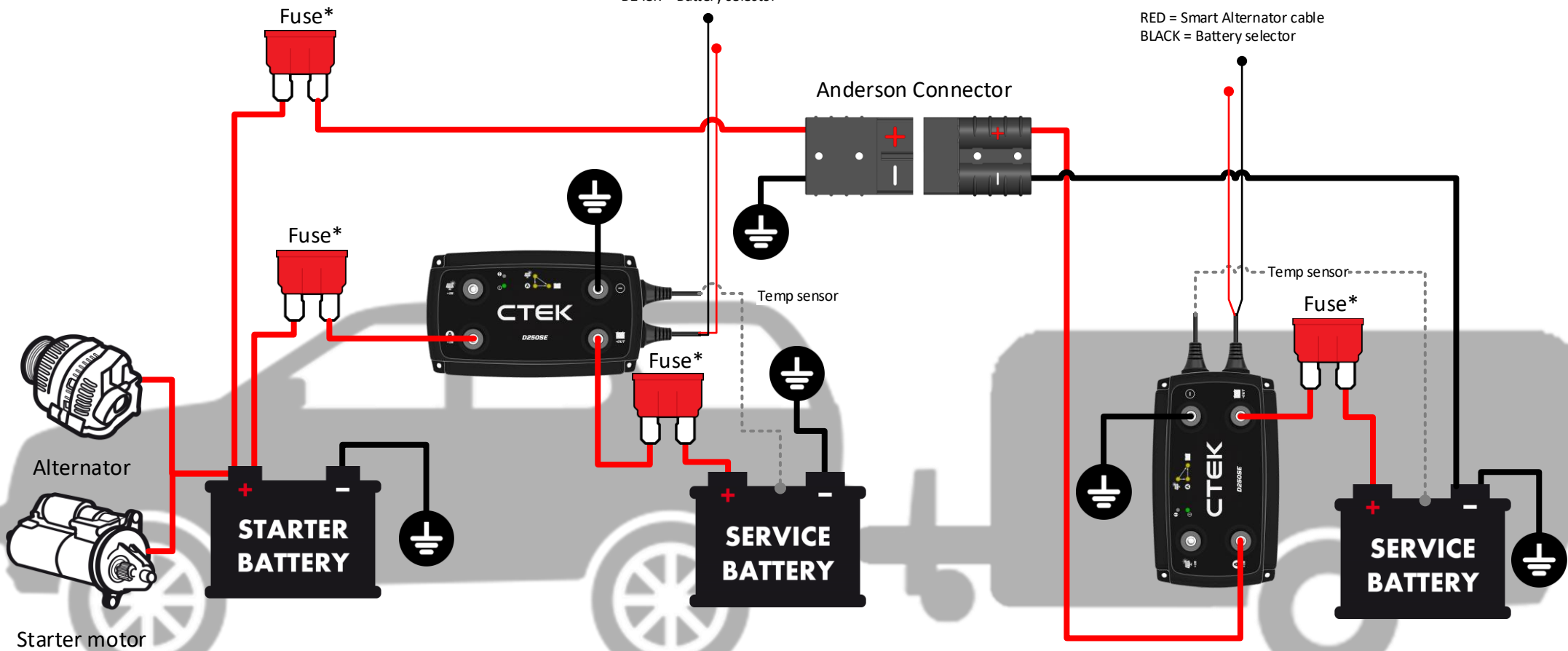

* Fuse recommended. Please verify directive for applicable installation regarding fuses

General Information

Starter battery:

A start battery should never be deeply discharged and should be capable of delivering high current for a short period of time.

The starter battery should be a Lead Acid battery designed for automotive applications. This does not affect the chemistry chosen for the Service battery

Service battery:

Also known as secondary battery, it should be of the type deep cycle batteries. The size should be 20Ah to 300Ah or even up to 800Ah with SMARTPASS 120S installed.

You can install several batteries in parallel in order to increase the total capacity (Ah) of your service battery bank.

If possible, the service battery should be installed in a well-ventilated space away from the engine bay, unless the battery is designed for it.

Install the service battery as close as possible to the charger, preferably not further away than 2m, which is the length of temperature sensor cable.

D250SE:

The D250SE is a DCDC charger, i.e. it is a dual input battery charger with an alternator or a solar panel as its power source. Please note that the alternator needs to be directly connected to a starter battery and that the D250SE is design to separate a starter and service battery

The charger will work in parallel with both SMARTPASS 120S as well as another D250SE.

The maintenance charge of your starter battery, that is facilitated with the help from a solar panel, is a small pulse charge (3sec with a 15 sec interval) that will compensate for the self discharge of your starter battery. Note, this should not be mistaken for a normal charge of the battery.

Install according to manual.

Fuses:

We recommend that all cables directly attached to a battery holds a fuse as close as possible to the battery in order to protect the cable.

See manual for fuse size.

Charge voltage:

You can choose between 14.4V (WET) /14.7V (AGM) / 14,2V (LiFePO4) on D250SE as the nominal charging voltage. This is done by connecting the black battery select cable to +12V for LiFePO4 mode or earth for AGM mode or not connected at all for WET mode.

Please note that the charge voltage levels are applied to the absorption phase (constant voltage phase), during bulk (constant current) the charge voltage will be lower but slowly increasing with the state of charge of the battery. See manual and Charge program charts for more information.

WET and AGM mode have a temperature regulated charge voltage, where the nominal voltage is reached at 25 degrees Celsius. Below that it is increased by 23mV per degree Celsius and vice versa if the temperature is higher.

Temperature sensor:

For D250SE and SMARTPASS 120S the temperature sensor ensures that the battery is only charged within its temperature range and helps detect a damaged battery that is overheating. In the latter case the charger will stop charging the battery and indicate fault. D250SE also uses the temperature sensor to enable temperature regulation of the charge voltage

General Information

Alternator:

The Alternator is the power source for both D250SE and SMARTPASS 120S, i.e. should be able to power the application where these units are installed.

Smart alternators was introduced in the Euro 5 & 6 engines, where they help the engine reduce its emissions by enabling brake regeneration. If you have a Smart alternator connect the red Smart Alternator signal cable to a +12V source that is live when the engine is running (for example contact no. 15 Ignition in the DIN 72552 standard) in order to get proper functionality from the D250SE / SMARTPASS 120S. Please note, that connecting this wire to a source that is live continuously will make the units active continuously as well, possibly rendering a starter battery with low state of charge.

If the Alternator has a sense wire connected to the Service battery make sure it is moved to the Starter battery when installing the D250SE/SMARTPASS120S. Note, a sense wire is typically found in Volvo Penta marine applications.

Cables:

For the best possible functionality follow the instructions in the manual regarding cable dimensions and make sure the cables are as short as possible in order to minimize voltage drops.

All cables should be firmly mounted and preferably in a cable protection tube minimizing wear and tear from the vibrations in your vehicle.

Busbars can be used to make the installation neat and tidy and the use of tubular ring terminals (size M8) properly crimped will reduce unnecessary resistance in the connections.

Note, the weaker cable recommendation to the negative terminal (D250SE) is chosen since it only carries current to the control electronics, not the charge current. The latter will flow through earth, which is connected to the negative terminal of your battery

Application:

You supply the D250SE mounted on the trailer from the starter battery with suggested Anderson connector between car and trailer.

This solution ensures that the battery on the trailer is properly recharged and is not affected by the voltage drop that can occur between the car and the trailer.